

Eclipse ImmersoJet Burners

Model 3"IJ

Version 2

Main Specifications

PARAMETER		BLOWER SIZE		
Blower Type		6" w.c. Packaged (60Hz)	10" w.c. Packaged (60Hz)	Remote Blower
Maximum Input (Btu/hr)		440,000	550,000	850,000
Minimum Input (Btu/hr)		28,000	28,000	28,000
Air Inlet Pressure ("w.c.) @Max. Input – Air pressure at burner inlet (Tap "A")		7.7	11.5	26.0
Blower Motor Horse Power		.33	.5	As Specified
Main Gas Pressure ("w.c.) into regulator	Max.	27.7	27.7	27.7
	Min.	10	14	27
Tube Backpressure ("w.c.)		1.6	2.6	6.1
Weight-less actuator (lbs)		95	100	60
CO emissions (ppm)		<100	<100	<100
Piping		N.P.T. or B.S.P.		
Flame Detection		Flamerod or U.V. Scanner.		
Fuel ⁽¹⁾		Natural gas, Propane, Butane <i>For any other mixed gas, contact Eclipse for orifice sizing.</i>		

(1) Different fuels require different nozzles and orificies.

- All information is based on laboratory testing with a tube effective length of 22 feet. Different tube sizes and conditions may affect the data.
- All information is based on standard tube design. Changes in the tube will alter performance and pressures.
- All inputs based upon gross caloric values.
- Eclipse reserves the right to change the construction and/or configuration of our products at any time without being obliged to adjust earlier supplies accordingly.
- Plumbing of air and gas will affect accuracy of orifice readings. All information is based on generally acceptable air and gas piping practices.

Performance Data

Typical Operational Curve & Ignition Zone (Nat. Gas, Propane & Butane)

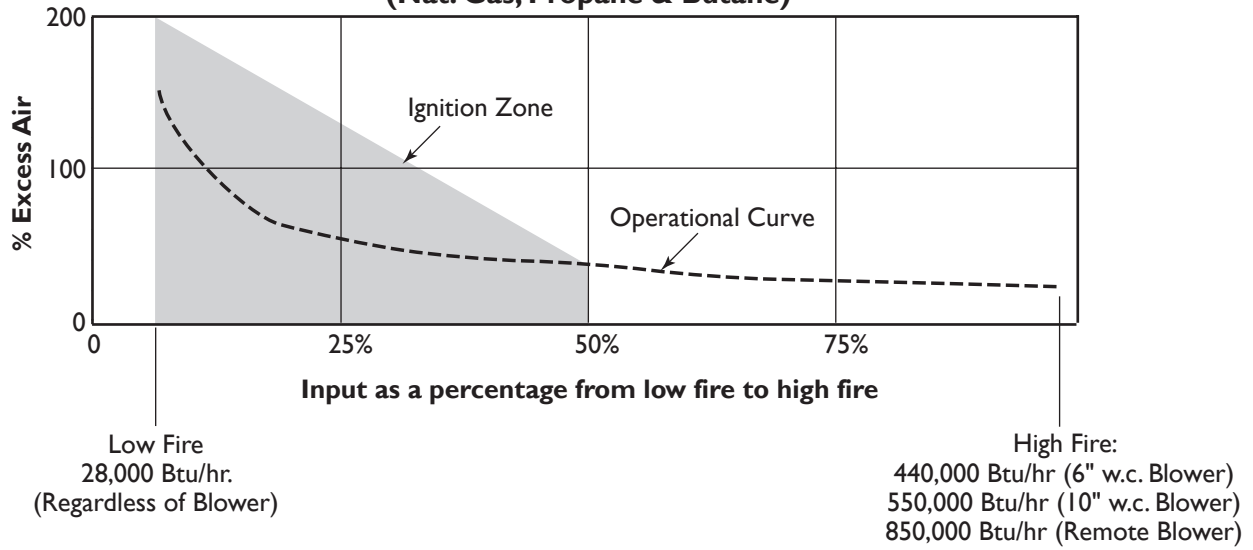

Gas Orifice ΔP vs. Input Measured from Tap "B" to Tap "D"

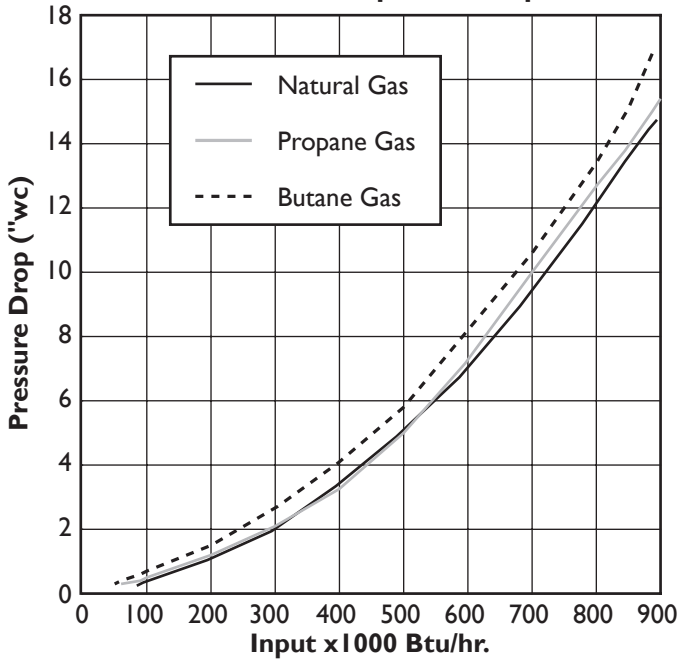

Air Orifice ΔP vs. Input @ 3% O₂ Measured from Tap "A" to Tap "C"

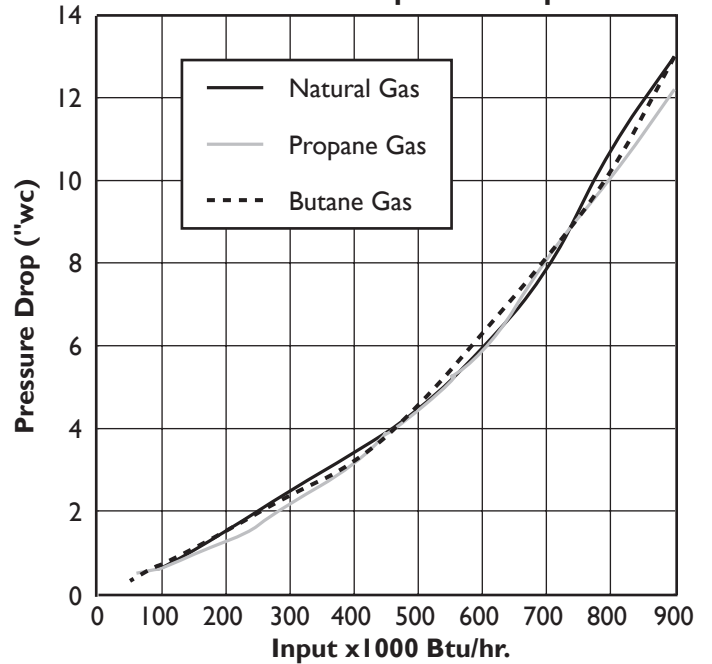

Dimensions & Specifications

Dimensions in mm (inches)

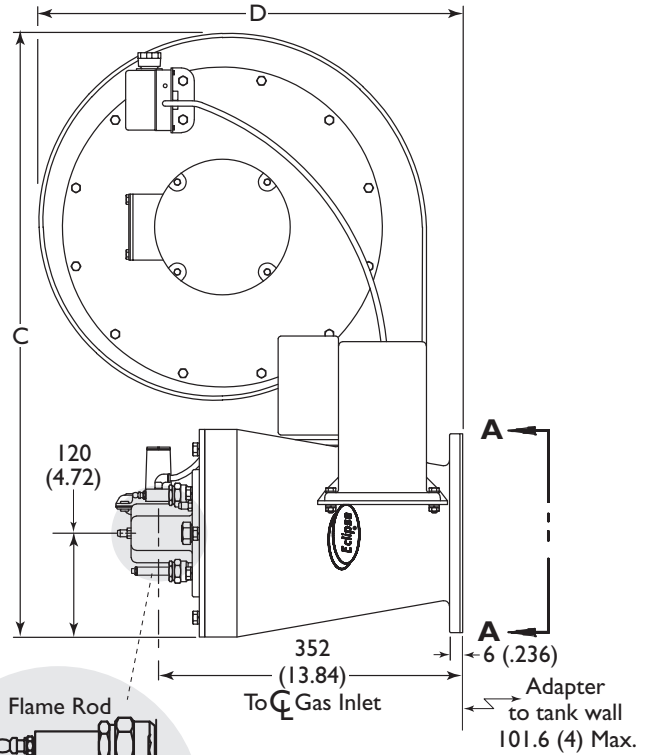
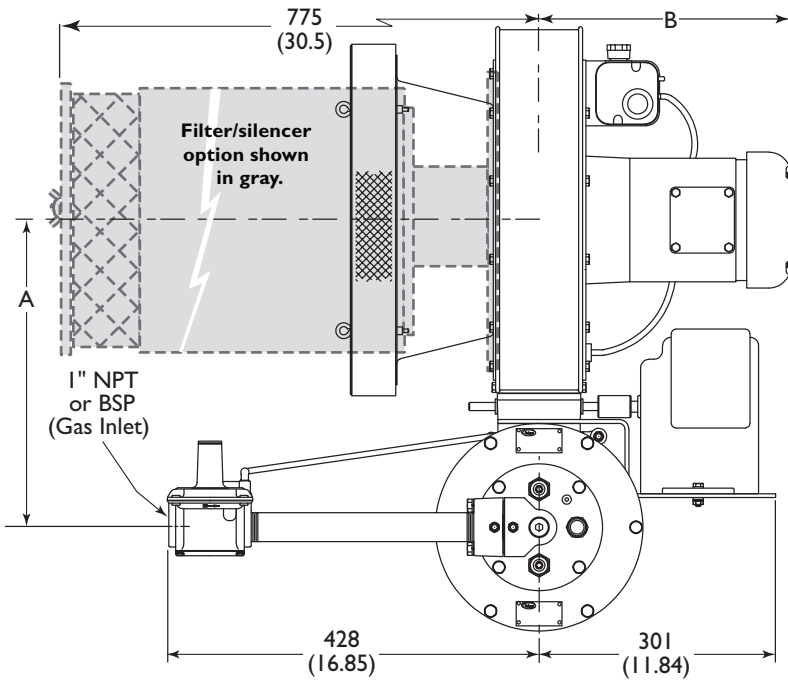

Note: See Remote Blower drawing below for Tap locations.

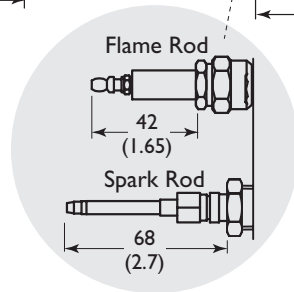
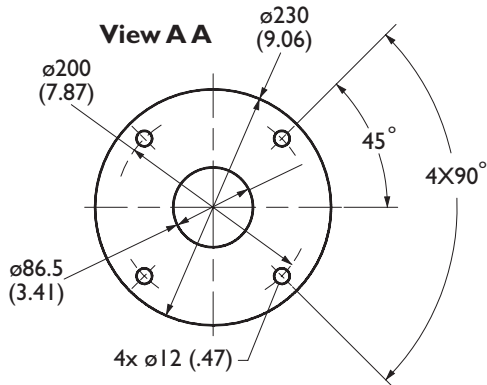

	A	B		C	D
		60Hz	50 Hz		
Low Pressure Blower	324 (12.74)	291 (11.44)	234 (9.20)	638 (25.08)	430 (16.91)
High Pressure Blower	353 (13.88)	291 (11.44)	255 (10.02)	698 (27.45)	490 (19.27)

Remote Blower

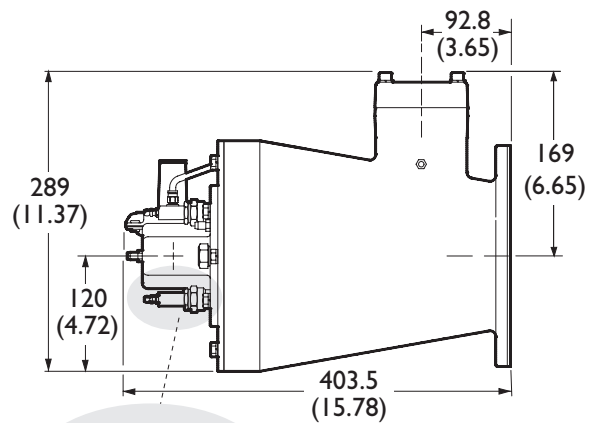
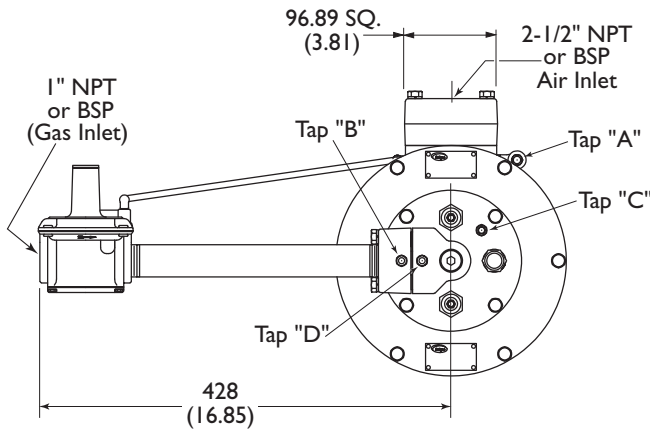

See above drawing for Spark and Flame Rod dimension details.



Offered By:

Power Equipment Company
2011 Williamsburg Road
Richmond, Virginia 23231
Phone (804) 236-3800
Fax (804) 236-3882

www.peconet.com